

K-DAXIS Wall Mounted Axial Fan



K-DAXIS fans can be used when low volume required. It is easy to install to walls and windows. Low noise level and power usage makes it an ideal solution for commercial usage.



MOTOR INSULATION CLASS	F CLASS
MOTOR PROTECTION CLASS	IP 44
MOTOR EFFICIENCY CLASS	IE2-IE3
MOTOR ENCLOSURE TYPE	EXTERNAL ROTOR MOTOR
MOTOR BRAND	KAYI
BODY MATERIAL	GALVANIZED SHEET METAL
BODY COATING	ELECTROSTATIC POWDER PAINT
IMPELLER MATERIAL	GALVANIZED SHEET METAL
DUTY CYCLE	IEC Duty Cycle-S1
WORKING AMBIENT TEMPERATURE	-20 - +50 °C
DIRECTIVE	IEC-60335-2-80, ISO 1940-1

MODEL	VOLTAGE (V)	FREQUENCY (Hz)	POWER (kW)	REVOLUTION (rpm)	FLOW RATE (m³/h)	NOISE LEVEL (dB(A))	PRICE
K-DAXIS 200	230	50	67	2.700	680	60	
K-DAXIS 250	230	50	110	2.640	1.500	70	
K-DAXIS 300	230	50	160	2.630	2.020	72	
K-DAXIS 350	230	50	240	2.280	3.110	78	

Values are for 0 Pa.

DRAWING

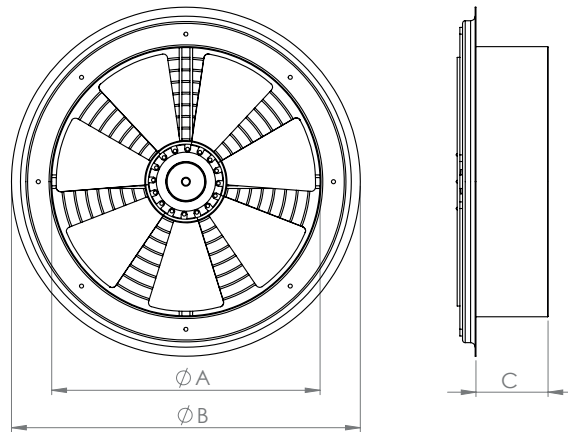

MODEL	A (mm)	B (mm)	C (mm)
K-DAXIS 200	200	290	70
K-DAXIS 250	250	340	70
K-DAXIS 300	300	390	80
K-DAXIS 350	350	440	80