



Axial box fans can be used in hard-to-install situations with its multiple connection point body. Default fan has an on-off switch and inbuilt sound attenuator.



MOTOR INSULATION CLASS	F CLASS
MOTOR PROTECTION CLASS	IP 55
MOTOR EFFICIENCY CLASS	IE2-IE3
MOTOR ENCLOSURE TYPE	TEFC
MOTOR BRAND	GAMAK-VOLT-WATT
BODY MATERIAL	GALVANIZED SHEET METAL
BODY COATING	OPTIONAL
IMPELLER MATERIAL	ALUMINIUM
DUTY CYCLE	IEC Duty Cycle-S1
WORKING AMBIENT TEMPERATURE	-20 - +50 °C
DIRECTIVE	IEC-60335-2-80, ISO 1940-1

MODEL	VOLTAGE (V)	FREQUENCY (Hz)	POWER (kW)	REVOLUTION (rpm)	FLOW RATE (m³/h)	NOISE LEVEL (dB(A))	PRICE
K-HAXI 400-5-25	380	50	0,37	1.450	2.950	61	
K-HAXI 450-5-25	380	50	0,55	1.456	4.250	64	
K-HAXI 500-5-25	380	50	0,55	1.453	6.000	67	
K-HAXI 560-5-25	380	50	0,75	1.466	8.200	70	
K-HAXI 630-5-30	380	50	1,10	1.465	13.600	75	
K-HAXI 710-5-30	380	50	1,50	1.472	19.400	78	
K-HAXI 800-5-30	380	50	2,20	1.459	26.000	80	
K-HAXI 800-5-35	380	50	3,00	1.463	31.500	84	
K-HAXI 900-5-35	380	50	4,00	1.471	40.000	85	
K-HAXI 900-5-40	380	50	5,50	1.472	45.500	88	
K-HAXI 1000-5-40	380	50	7,50	1.478	55.000	89	
K-HAXI 900-8-40	380	50	11,00	1.454	47.000	89	
K-HAXI 1000-8-40	380	50	15,00	1.456	62.500	92	
K-HAXI 1000-8-45	380	50	18,50	1.458	70.000	94	
K-HAXI 1120-8-40	380	50	22,00	1.471	87.500	95	
K-HAXI 1120-8-45	380	50	30,00	1.474	96.000	97	

Values are for 0 Pa.



PANEL	
SIZE	PRICE
5,5 kW	
7,5 kW	
11,0 kW	
15,0 kW	
18,5 kW	
22,0 kW	
30,0 kW	

## OPTIONS

- Electro-Static Powder Coating
- Custom Fans For Specific Flow Rate and Pressure
- 5, 8, 12, or 16 Blade Fan
- Aluminium or Plastic Blades
- System Automation
- Two-Speed Motor
- Smoke Exhaust Model

## DRAWING

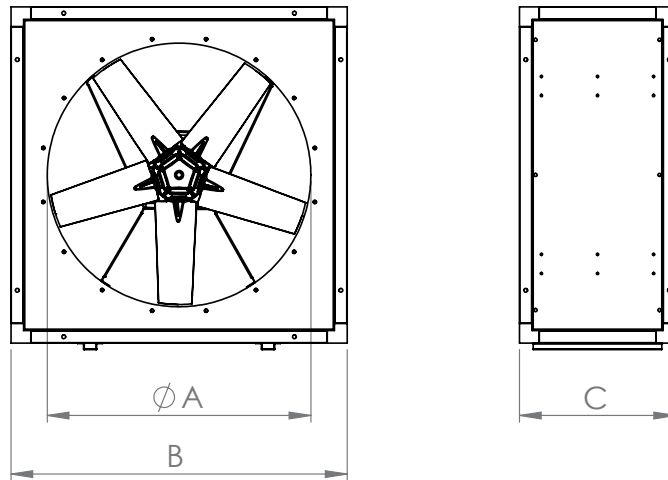

MODEL	A (mm)	B (mm)	C (mm)
K-HAXI 400	400	620	425
K-HAXI 450	450	670	425
K-HAXI 500	500	720	425
K-HAXI 560	560	780	425
K-HAXI 630	630	850	425
K-HAXI 710	710	930	425
K-HAXI 800	800	1020	425
K-HAXI 900	900	1120	525
K-HAXI 1000	1000	1220	525
K-HAXI 1120	1120	1340	525

## PERFORMANCE CURVES

K-HAXI 400-5-25

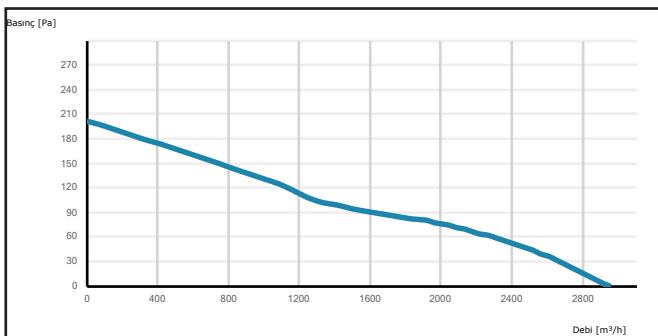

K-HAXI 450-5-25

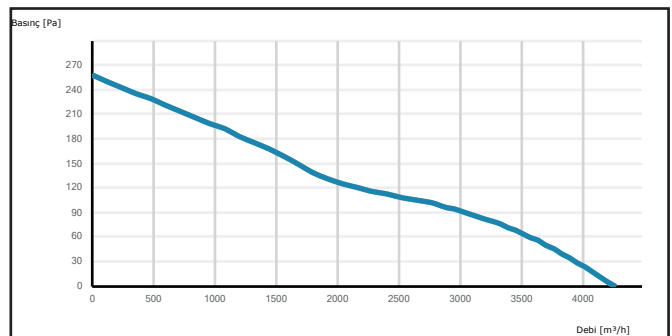

K-HAXI 500-5-25

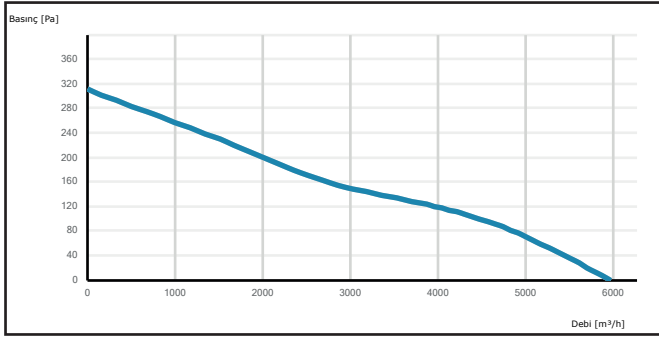

K-HAXI 560-5-25

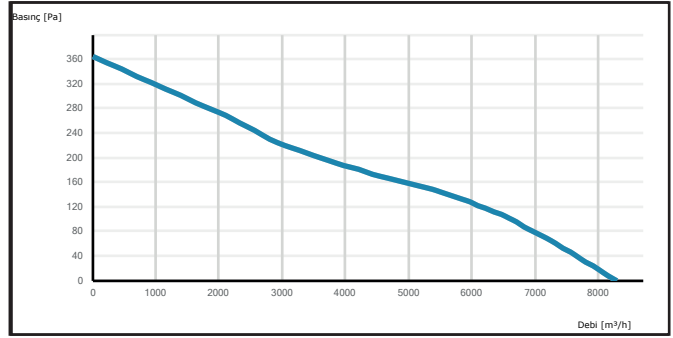

K-HAXI 630-5-30

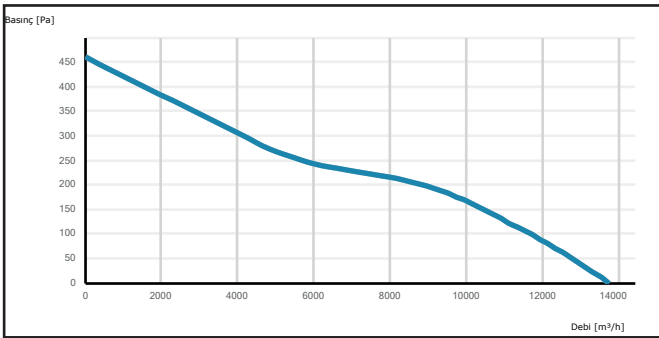

K-HAXI 710-5-30

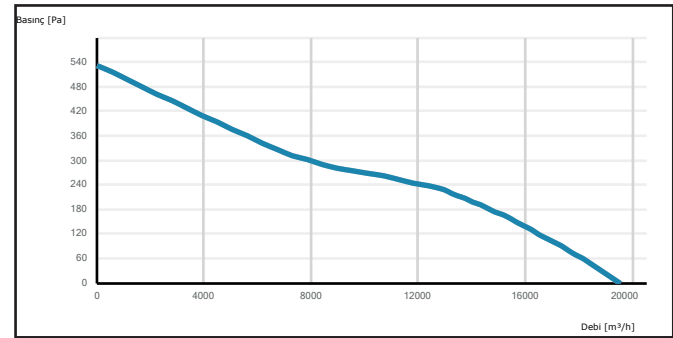

K-HAXI 800-5-30

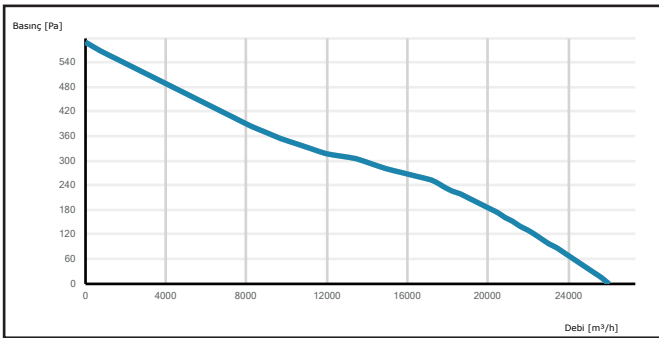

K-HAXI 800-5-35

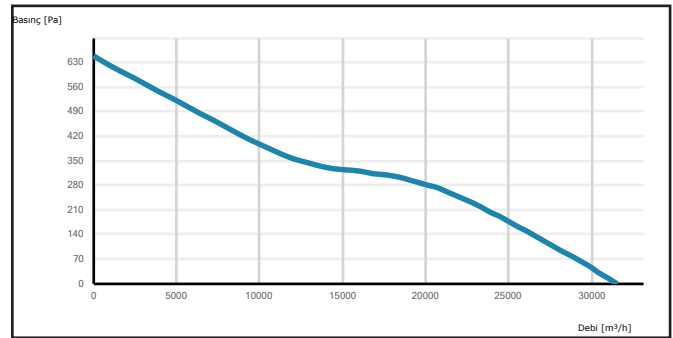

K-HAXI 900-5-35

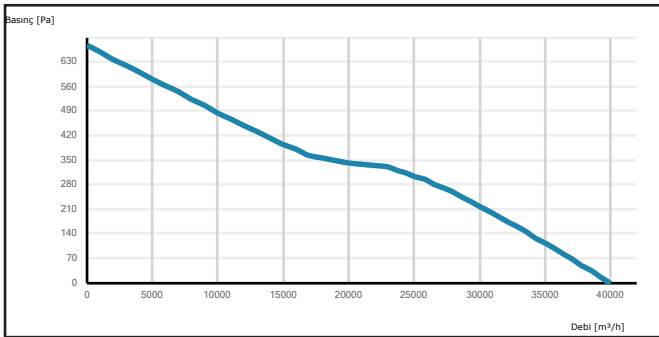

K-HAXI 900-5-40

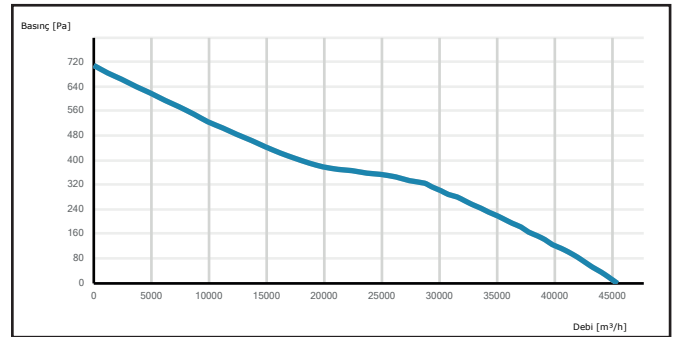

K-HAXI 1000-5-40

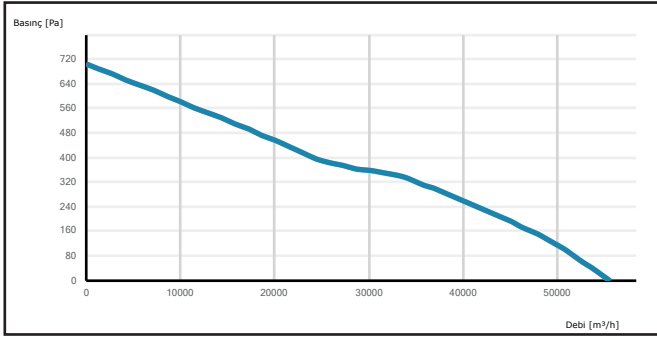

K-HAXI 900-8-40

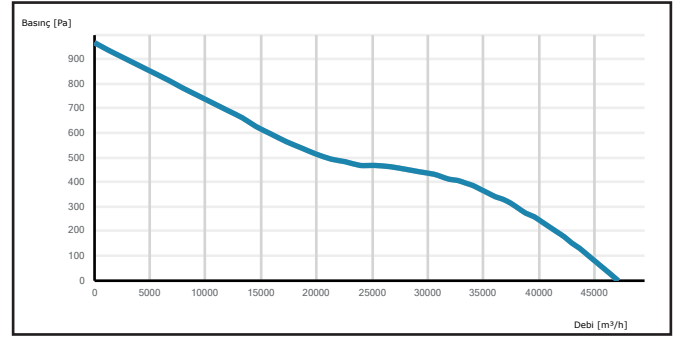

K-HAXI 1000-8-40

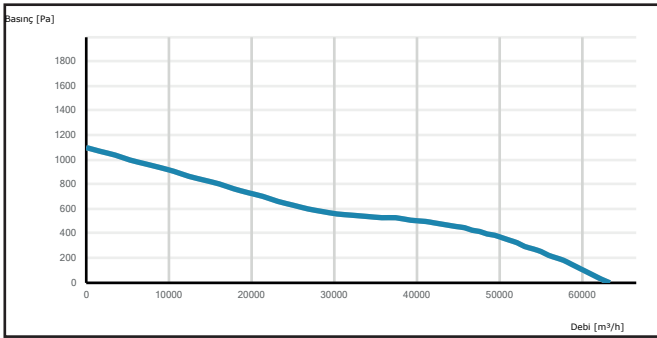

K-HAXI 1000-8-45

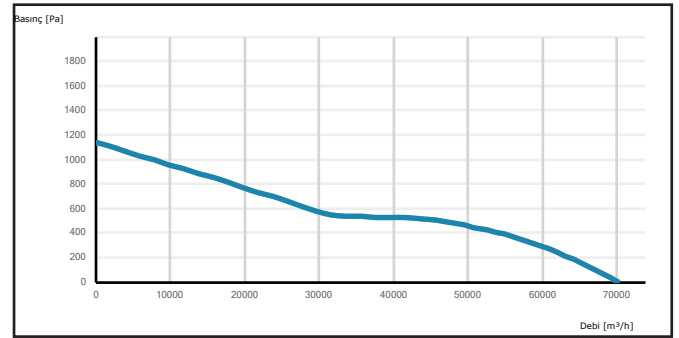

K-HAXI 1120-8-40

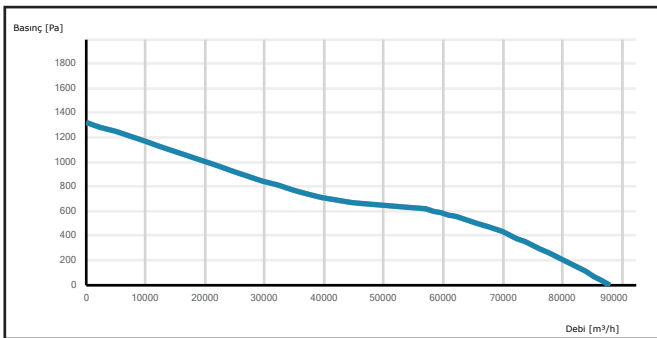

K-HAXI 1120-8-45

