

K-JRADF4 - Centrifugal Jet Fan - F400



Centrifugal Jet Fans can be used when there is height issue in the parking lots.



MOTOR INSULATION CLASS	H CLASS
MOTOR PROTECTION CLASS	IP 54-IP 55
MOTOR EFFICIENCY CLASS	IE1-IE2
MOTOR ENCLOSURE TYPE	TEAO
MOTOR BRAND	WEG-GAMAK
BODY MATERIAL	GALVANIZED SHEET METAL
BODY COATING	OPTIONAL
IMPELLER MATERIAL	GALVANIZED SHEET METAL
DUTY CYCLE	IEC Duty Cycle-S1
WORKING AMBIENT TEMPERATURE	-20 - +50 °C
DIRECTIVE	IEC-60335-2-80, ISO 1940-1, EN 12101-3

MODEL	FLOW RATE (m³/h)	AIR SPEED (m/s)	THRUST FORCE (N)	REVOLUTION (rpm)	MOTOR POWER (kW)	NOISE LEVEL (dB(A)-1m)	PRICE
K-JRAD 50	2.850 - 5.760	10,0 - 20,0	13 - 50	750 - 1.500	0,30 - 1,20	38 - 54	
K-JRAD 70	3.500 - 7.009	12,2 - 24,4	19 - 70	750 - 1.500	0,55 - 2,20	43 - 58	
K-JRAD 90	3.800 - 7.641	13,3 - 26,6	25 - 90	750 - 1.500	0,55 - 2,20	46 - 62	

OPTIONS

- SYSTEM AUTOMATION
- CFD ANALYSIS

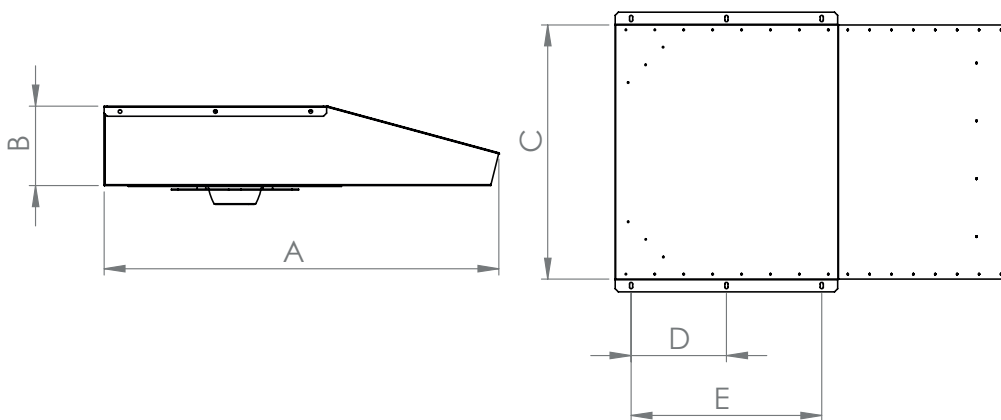

MODEL	A (mm)	B (mm)	C (mm)	D (mm)	E (mm)
K-JRAD 50	1215	250	800	300	600
K-JRAD 70	1300	300	840	300	600
K-JRAD 90	1300	300	840	300	600