

K-TAXI - Axial Smoke Exhaust Fan - F300

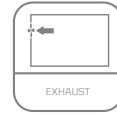

Axial Smoke Exhaust Fans can keep working for two hours at 300 °C and in combination with Jet Fans can be used to extract smoke from parking lots in case of fire.



MOTOR INSULATION CLASS	H CLASS
MOTOR PROTECTION CLASS	IP 54-IP 55
MOTOR EFFICIENCY CLASS	IE1-IE2
MOTOR ENCLOSURE TYPE	TEAO
MOTOR BRAND	WEG-GAMAK
BODY MATERIAL	GALVANIZED SHEET METAL
BODY COATING	OPTIONAL
IMPELLER MATERIAL	ALUMINIUM
DUTY CYCLE	IEC Duty Cycle-S1
WORKING AMBIENT TEMPERATURE	-20 - +50 °C
DIRECTIVE	IEC-60335-2-80, ISO 1940-1, EN 12101-3

MODEL	VOLTAGE (V)	FREQUENCY (Hz)	POWER (kW)	REVOLUTION (rpm)	FLOW RATE (m³/h)	NOISE LEVEL (dB(A))	PRICE
K-TAXI 450-5-25	380	50	0,55	1.456	4.250	69	
K-TAXI 500-5-25	380	50	0,55	1.453	6.000	72	
K-TAXI 560-5-25	380	50	0,75	1.466	8.200	75	
K-TAXI 630-5-30	380	50	1,10	1.465	13.600	80	
K-TAXI 710-5-30	380	50	1,50	1.472	19.400	83	
K-TAXI 800-5-30	380	50	2,20	1.459	26.000	85	
K-TAXI 800-5-35	380	50	3,00	1.463	31.500	89	
K-TAXI 900-5-35	380	50	4,00	1.471	40.000	90	
K-TAXI 900-5-40	380	50	5,50	1.472	45.500	93	
K-TAXI 1000-5-40	380	50	7,50	1.478	55.000	94	
K-TAXI 900-8-40	380	50	11,00	1.454	47.000	94	
K-TAXI 1000-8-40	380	50	15,00	1.456	62.500	97	
K-TAXI 1000-8-45	380	50	18,50	1.458	70.000	99	
K-TAXI 1120-8-40	380	50	22,00	1.471	87.500	100	
K-TAXI 1120-8-45	380	50	30,00	1.474	96.000	102	

Values are for 0 Pa.

OPTIONS



GRILLE GUARD	
SIZE	PRICE
450	
500	
560	
630	
710	
800	
900	
1000	
1120	

SUPPORT FEET	
SIZE	PRICE
450	
500	
560	
630	
710	
800	
900	
1000	
1120	

DUCT FLANGE	
SIZE	PRICE
450	
500	
560	
630	
710	
800	
900	
1000	
1120	

CONNECTOR	
SIZE	PRICE
450	
500	
560	
630	
710	
800	
900	
1000	
1120	

RUBBER PAD	
SIZE	PRICE
450	
500	
560	
630	
710	
800	
900	
1000	
1120	

SPRING	
SIZE	PRICE
450	
500	
560	
630	
710	
800	
900	
1000	
1120	

OPTIONS

- Custom Fans For Specific Flow Rate and Pressure
- 5, 8, 12, or 16 Blade Fan
- System Automation
- Two-Speed Motor

DRAWING

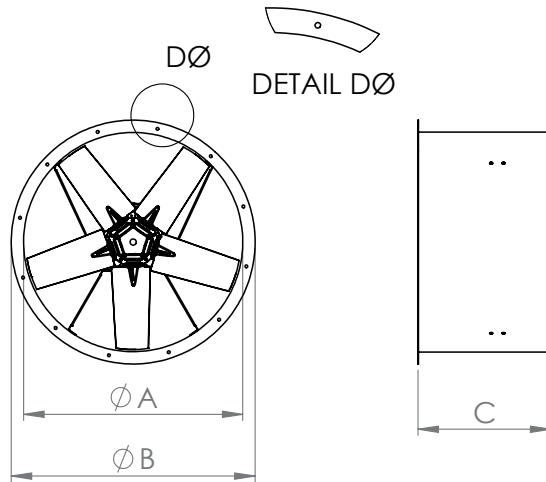

MODEL	A (mm)	B (mm)	C (mm)	D (mm)	N
K-TAXI 450	450	530	320	11	8
K-TAXI 500	500	580	320	11	8
K-TAXI 560	560	640	320	11	12
K-TAXI 630	630	710	420	11	12
K-TAXI 710	710	790	420	11	12
K-TAXI 800	800	880	420	11	16
K-TAXI 900	900	980	520	11	16
K-TAXI 1000	1000	1080	520	11	16
K-TAXI 1120	1120	1200	520	11	16

N: Number of Holes

PERFORMANCE CURVES

K-TAXI 450-5-25

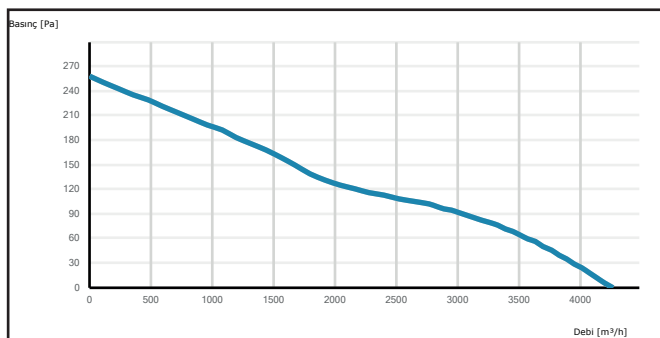

K-TAXI 500-5-25

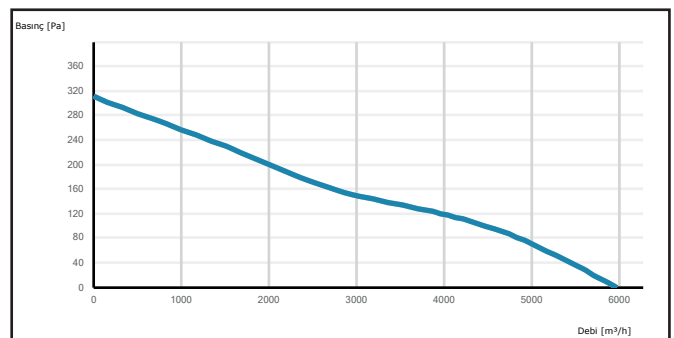

K-TAXI 560-5-25

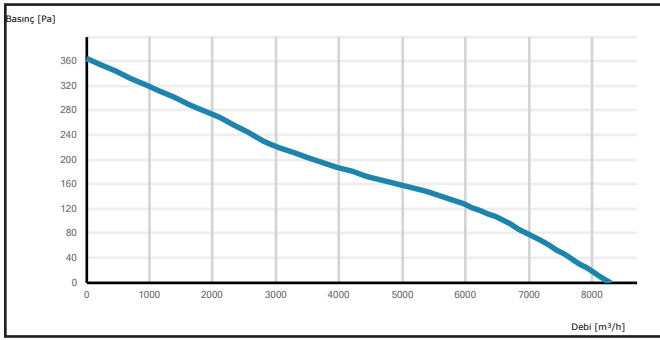

K-TAXI 630-5-30

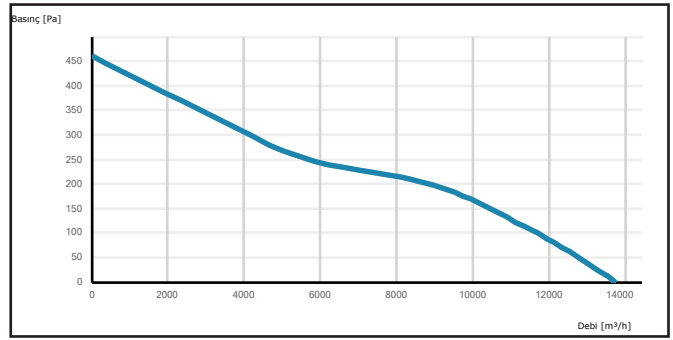

K-TAXI 710-5-30

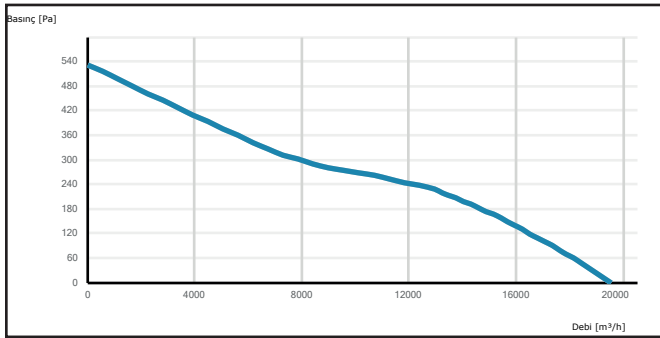

K-TAXI 800-5-30

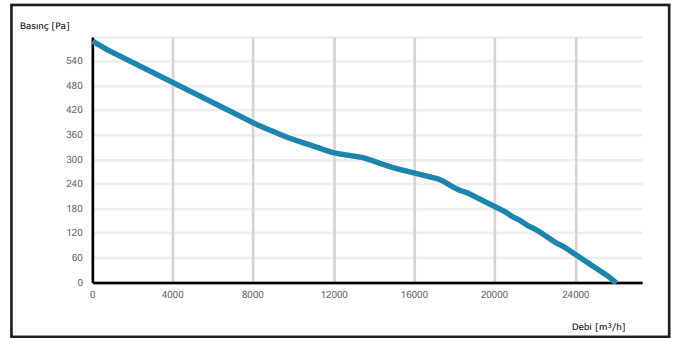

K-TAXI 800-5-35

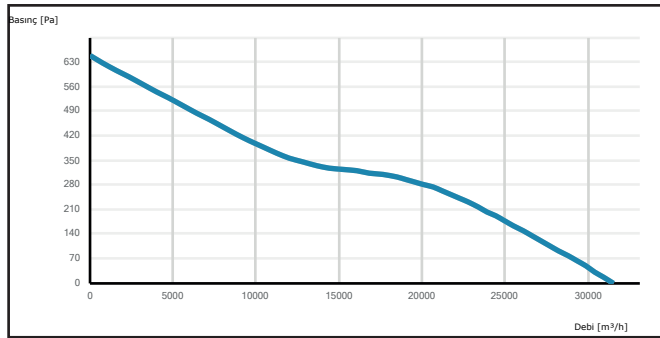

K-TAXI 900-5-35

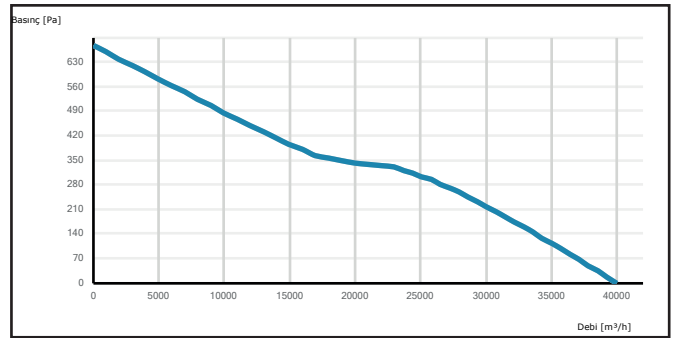

K-TAXI 900-5-40

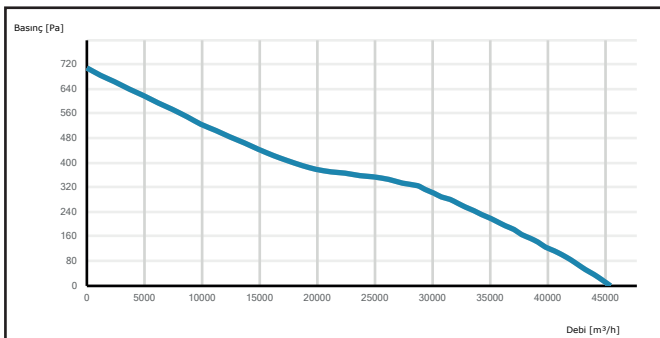

K-TAXI 1000-5-40

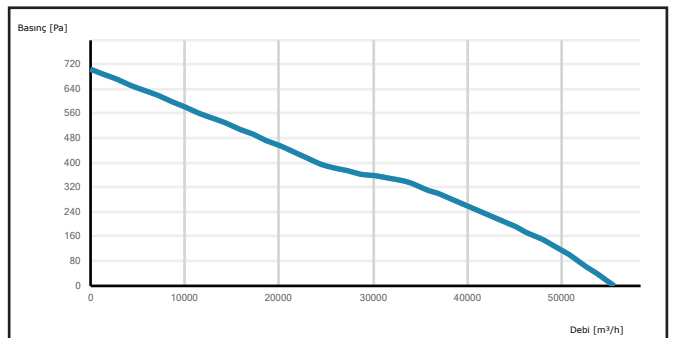

K-TAXI 900-8-40

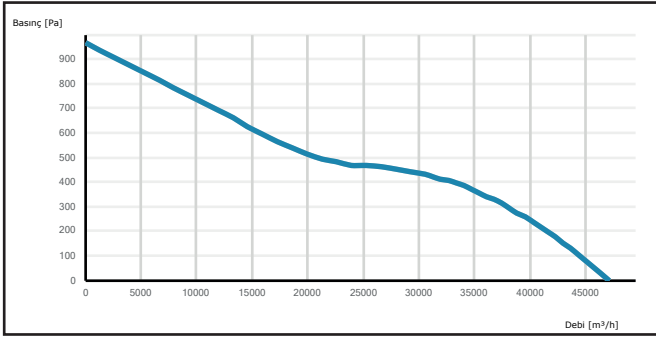

K-TAXI 1000-8-40

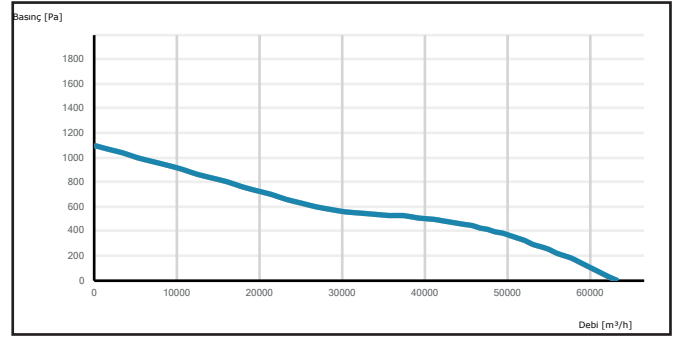

K-TAXI 1000-8-45

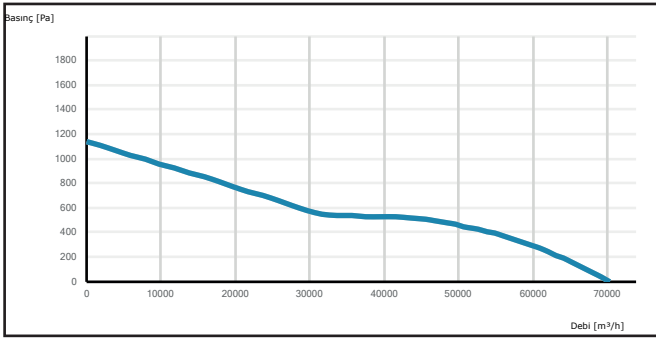

K-TAXI 1120-8-40

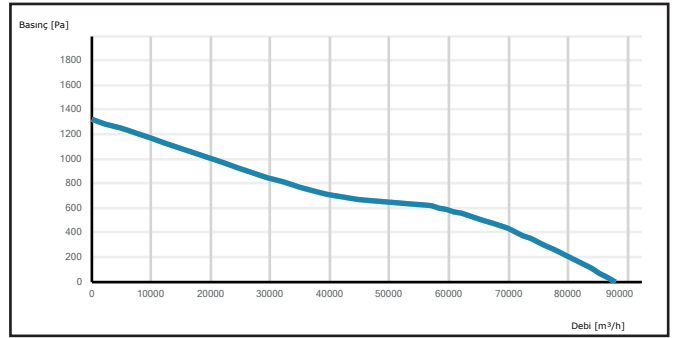

K-TAXI 1120-8-45

