

KAL-K Ventilation Unit Backward Curved Belt Driven Radial Fan



KAL-K Ventilation Unit can be used in the range of 500 m³/h to 100.000 m³/h air flow capacity, G4, G2, F7 etc. applicable as filter and production is made in different types and sizes if desired.

* Housing structure is aluminum carcass and the corners are produced as plastic and aluminum components.

* Panel thicknesses are produced as standard 25mm or optional 50mm rockwool insulated double skin, Electrostatic Powder Painted and Leak-proof Gasket.

* Double Inlet Radial Fans with Belt Driven Assemblies are Used inside.

* Easy installation is possible with the compact design.

* It is used for supply, exhaust or pressurization for the ventilation.

Factory, Hospital, Office, Laboratory, Shopping Center (shopping malls), Cafe, Restaurants, Parking lots etc. It is suitable for use in all structures which has air duct system



MOTOR INSULATION CLASS	F CLASS	BODY MATERIAL	GALVANIZED SHEET METAL
MOTOR PROTECTION CLASS	IP 55	BODY COATING	ELECTROSTATIC POWDER PAINT
MOTOR EFFICIENCY CLASS	IE2-IE3	IMPELLER MATERIAL	GALVANIZED SHEET METAL
MOTOR ENCLOSURE TYPE	TEFC	DUTY CYCLE	IEC Duty Cycle-S1
MOTOR BRAND	GAMAK-VOLT-WATT	WORKING AMBIENT TEMPERATURE	-20 - +50 °C
		DIRECTIVE	IEC-60335-2-80, ISO 1940-1

MODEL	VOLTAGE (V)	FREQUENCY (Hz)	POWER (kW)	REVOLUTION (rpm)	FLOW RATE (m ³ /h)	PRICE
KAL-K 280 A	230 or 380	50	1,1	1400	4.600	
KAL-K 280 B	230 or 380	50	2,2	1400	5.800	
KAL-K 315 A	230 or 380	50	2,2	1400	7.200	
KAL-K 315 B	230 or 380	50	3	1400	8.200	
KAL-K 355 A	230 or 380	50	3	1400	9.500	
KAL-K 355 B	380	50	4	1400	10.250	
KAL-K 400 A	380	50	4	1400	13.100	
KAL-K 400 B	380	50	5,5	1400	15.000	
KAL-K 450 A	380	50	5,5	1400	16.000	
KAL-K 450 B	380	50	7,5	1400	18.500	
KAL-K 500 A	380	50	7,5	1400	20.000	
KAL-K 500 B	380	50	11	1400	22.400	
KAL-K 560 A	380	50	11	1400	23.000	
KAL-K 560 B	380	50	15	1400	29.500	
KAL-K 630 A	380	50	15	1400	31.500	
KAL-K 630 B	380	50	18,5	1400	37.000	

Values are for 0 Pa.

DRAWING

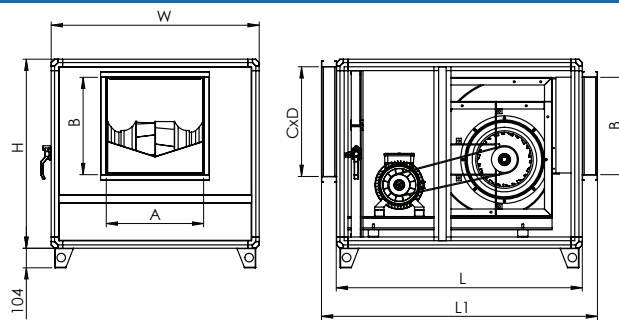

MODEL	L (mm)	W (mm)	H (mm)	A (mm)	B (mm)	C (mm)	D (mm)
KAL-K 280 A	1050	750	750	361	361	295	670
KAL-K 280 B	1050	750	750	361	361	295	670
KAL-K 315 A	1100	850	850	405	405	345	770
KAL-K 315 B	1100	850	850	405	405	345	770
KAL-K 355 A	1200	900	900	455	455	370	820
KAL-K 355 B	1200	900	900	455	455	370	820
KAL-K 400 A	1300	1100	1100	510	510	470	1020
KAL-K 400 B	1300	1100	1100	510	510	470	1020
KAL-K 450 A	1400	1200	1200	570	570	520	1120
KAL-K 450 B	1400	1200	1200	570	570	520	1120
KAL-K 500 A	1600	1350	1350	640	640	595	1270
KAL-K 500 B	1600	1350	1350	640	640	595	1270
KAL-K 560 A	1700	1500	1500	715	715	670	1420
KAL-K 560 B	1700	1500	1500	715	715	670	1420
KAL-K 630 A	1950	1650	1650	843	843	745	1570
KAL-K 630 B	1950	1650	1650	843	843	745	1570

DIRECTION-1

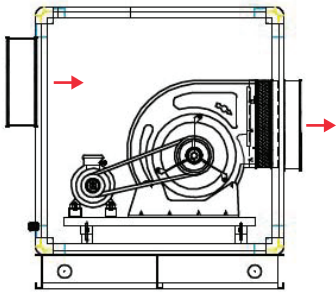

DIRECTION-2

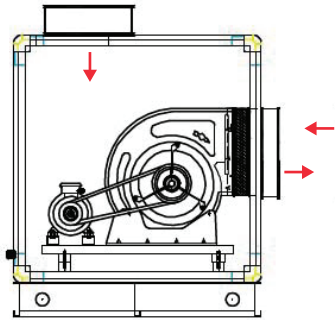

DIRECTION-3

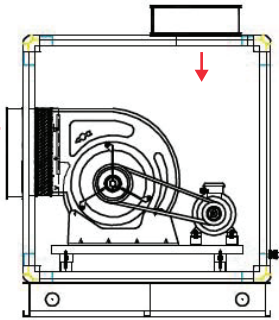

DIRECTION-4

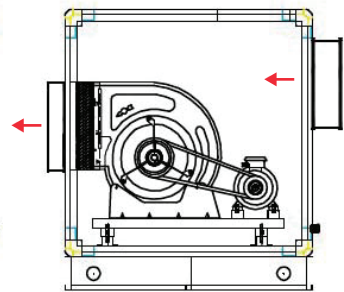

DIRECTION-5

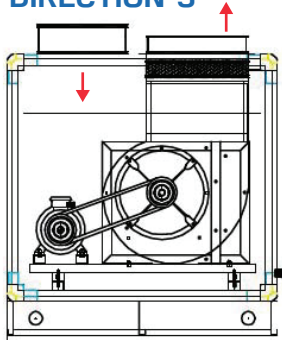

DIRECTION-6

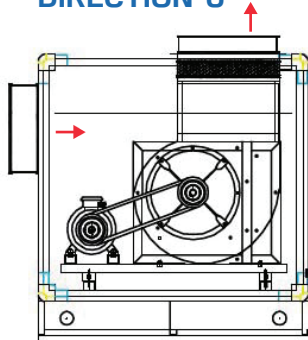

DIRECTION-7

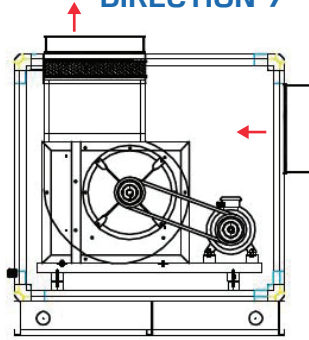

DIRECTION-8

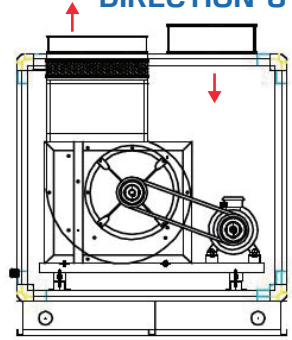

DIRECTION-9

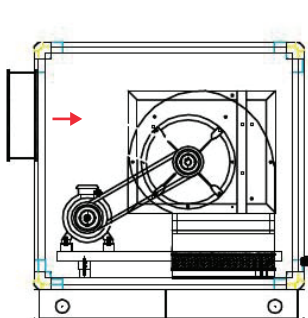

DIRECTION-10

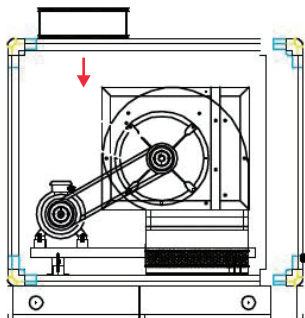

DIRECTION-11

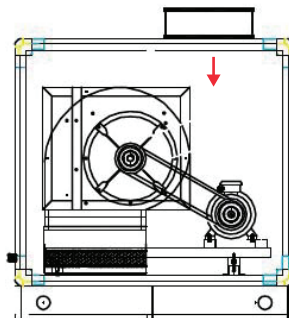

DIRECTION-12

